

Moldex3D Users' Meeting - Italy 2016

Friday, Jun 24
Golf Club Lecco



Moldex3D

**Deformazione: analisi, simulazione e
verifica metrologica**

U-Shin Italia Spa – Pianezza Torino
Marco Buzzi - Mold Engineering

Global U-Shin

- Create the world leader in Access Mechanisms -

U-Shin, global Japanese company founded in 1926 and specialized in access mechanisms systems for vehicle and control panels, is an automotive part supplier which provides robust, reliable, competitive and innovative solutions to meet expectations of most demanding customers all around the world.

Present in 15 countries, U-Shin is a global company that realized 40% of its turnover in Asia, 40% in Europe/Russia and 20% in North and South America.

With a strong portfolio of over 2.500 patents, U-Shin has a unique expertise in the electrical, mechanical, optical, electronic, cosmetic, and implemented in a wide range of products. With 12 Development Centers scattered around the world, U-Shin has the ability to deploy worldwide global projects and offering reduced development costs and proven solutions.

It is in 2013 that U-Shin bought a part of Valeo specialized in access mechanisms in order to reinforce its position around the globe.

Today, world leader in access mechanisms, U-Shin creates intuitive, innovative and differentiating product in order to position itself as the leading multi-specialist in its category.

Creating and Offering the New Value



Global U-Shin

- Create the world leader in Access Mechanisms -



Global Footprint

15 countries

Strong presence in Europe
and Asia



**Global Customer
Portfolio**

Creating and Offering the New Value



Global U-Shin

- Key figures -



8500
Employees



2 Product Lines
Handles & Latches - Locksets

7 Technology Poles
Latches, lockset, Handles, PCS, ESCL
Switch, Heater Control

Creating and Offering the New Value



Global U-Shin - Key Figures -



U-Shin realized

- 40% of its turnover in Asia,
- 40% in Europe/Russia,
- 20% in North and South America

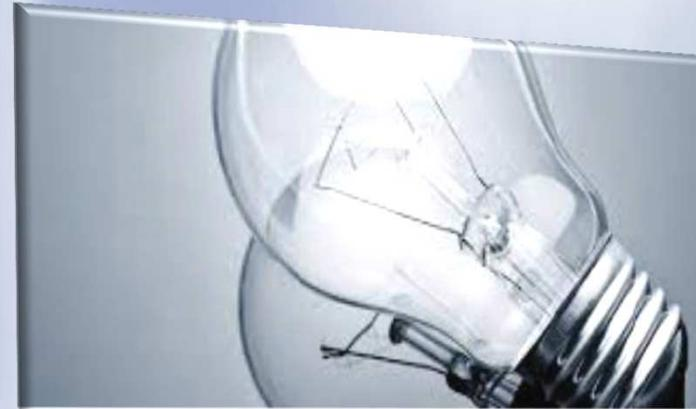

**Strong portfolio of
over 2.500 patents**

Creating and Offering the New Value



u-shin

MANIGLIA
MECCANICA

STRUTTURA

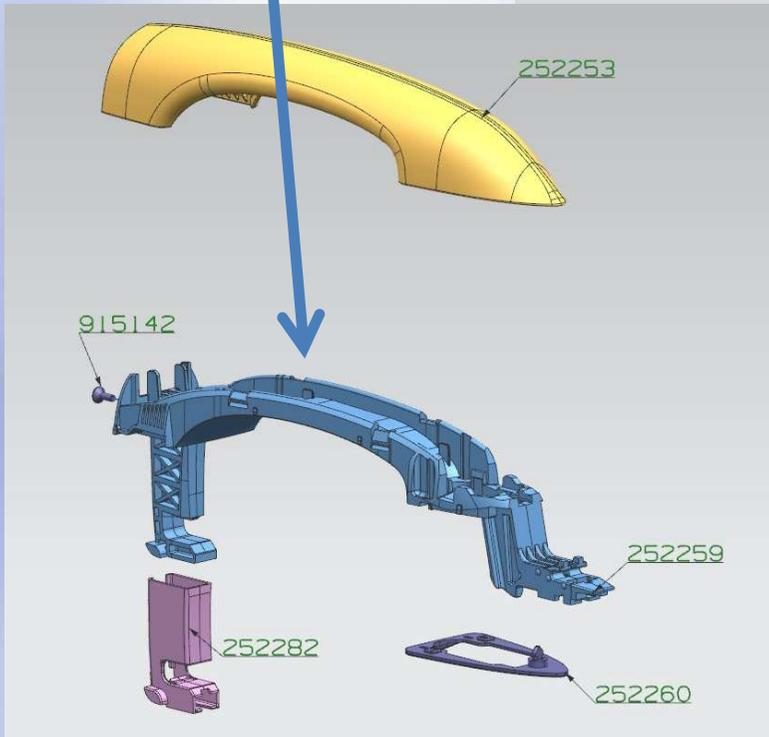
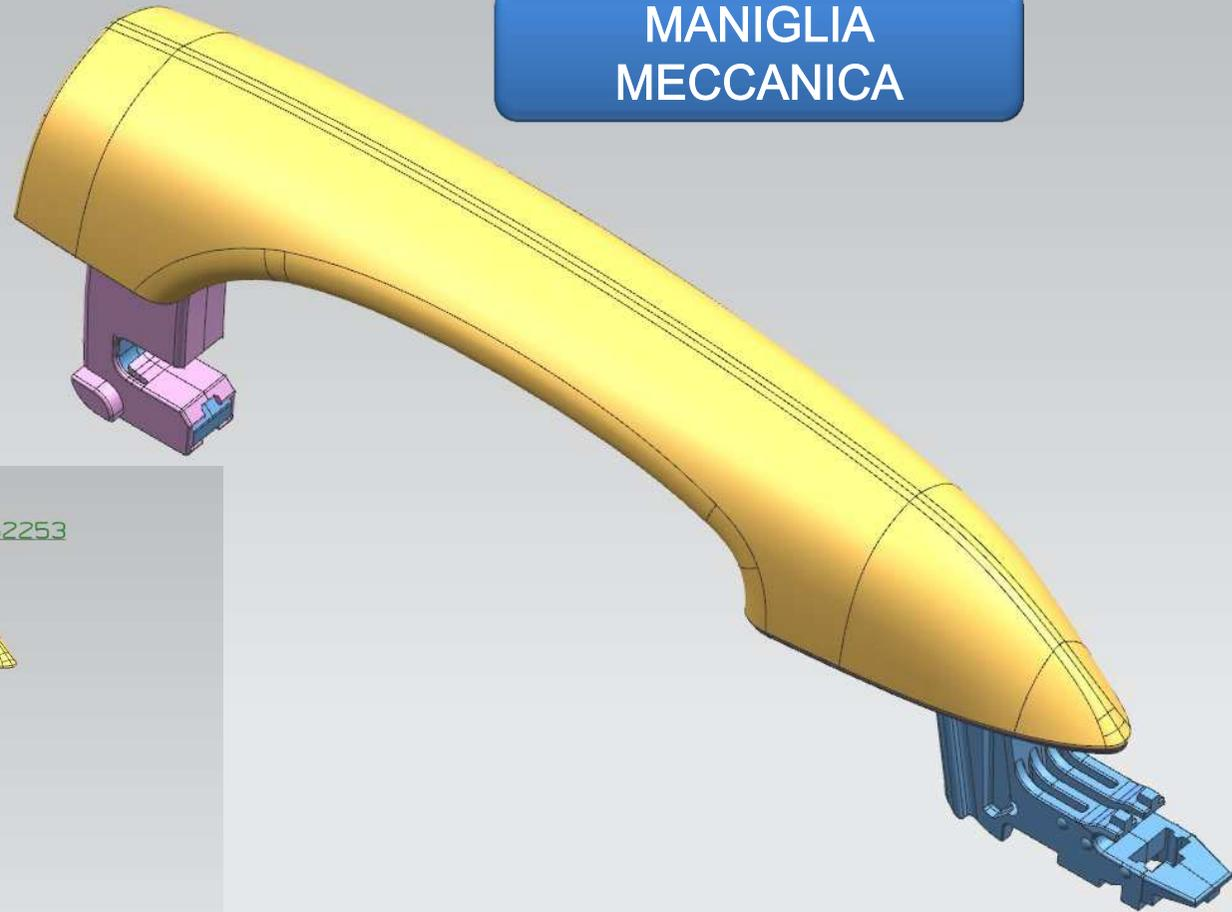

Creating and Offering the New Value



u-shin

STRUTTURA

ESTRATTO
DAL
DISEGNO

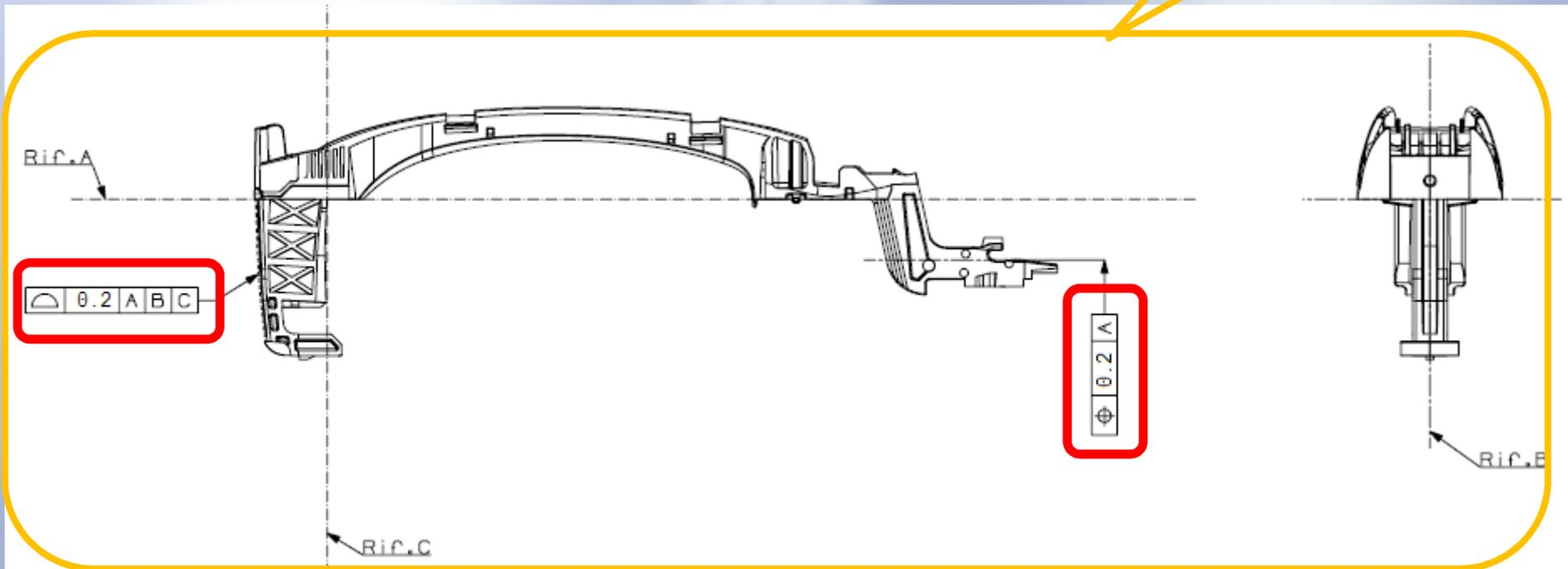

Creating and Offering the New Value



u-shin

3D ELEMENTO
DRAFT



MOLDEX 3D
FPW



MODIFICHE PRODOTTO
PER MIGLIORAMENTO
PROCESSABILITA'

3D ELEMENTO
MODIFICATO
REV.1



MOLDEX 3D
FPW



DESIGN FREEZE

3D ELEMENTO
FREEZE



MOLDEX 3D
CFPCW



MODIFICA 3D STAMPO
CON REVERSE WARP
"STL"

Creating and Offering the New Value



u-shin

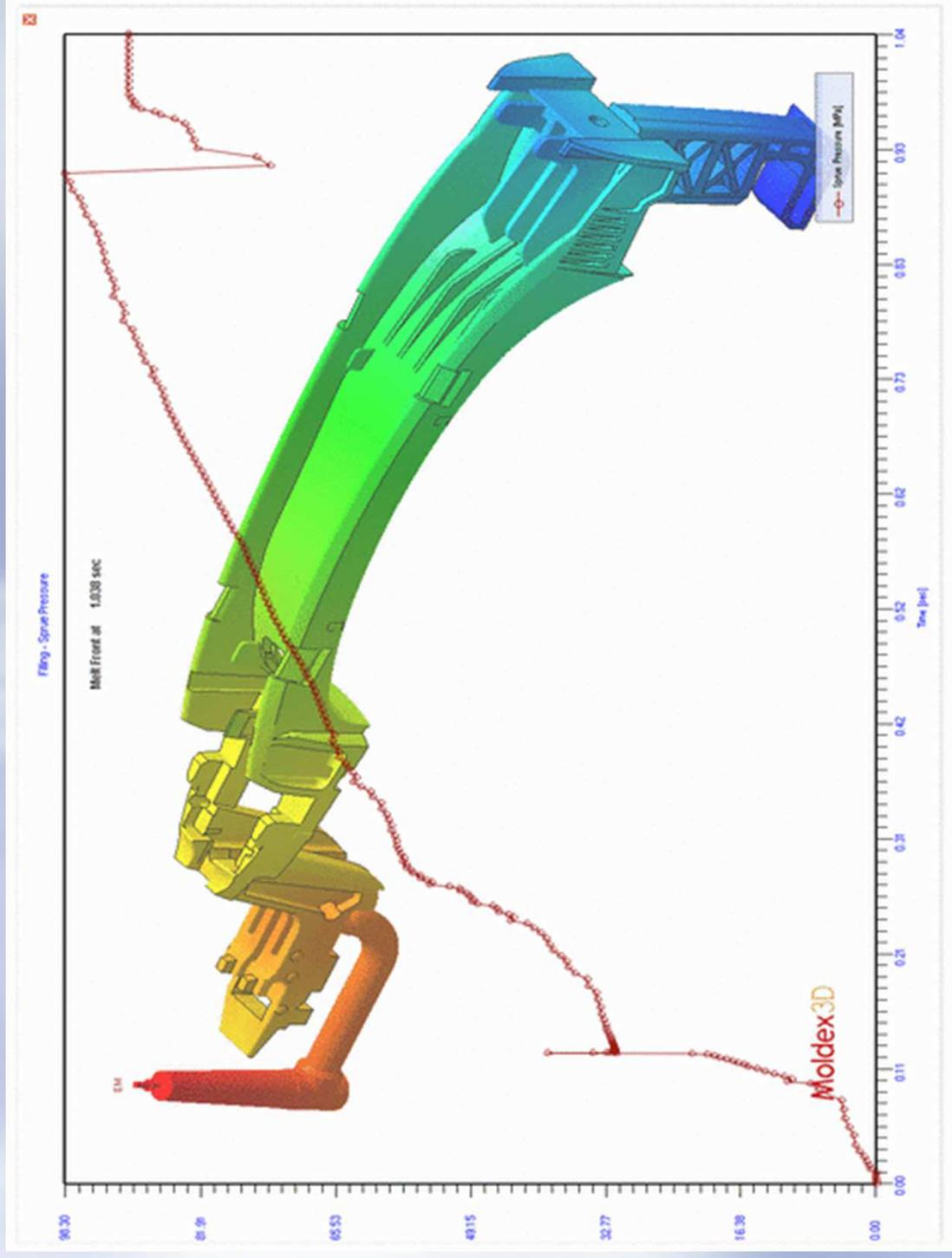

Creating and Offering the New Value

U-shin

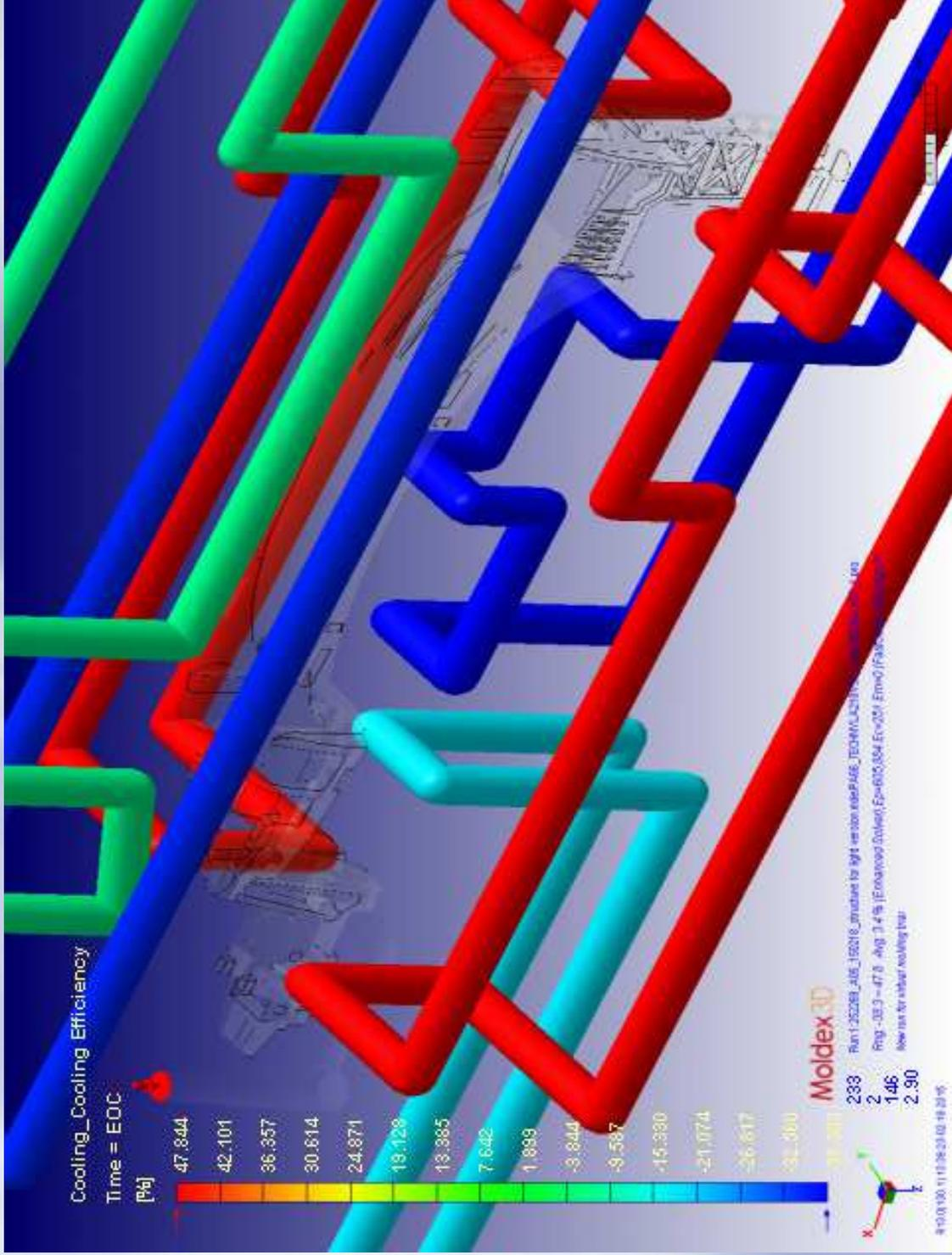

Creating and Offering the New Value

ur-shin

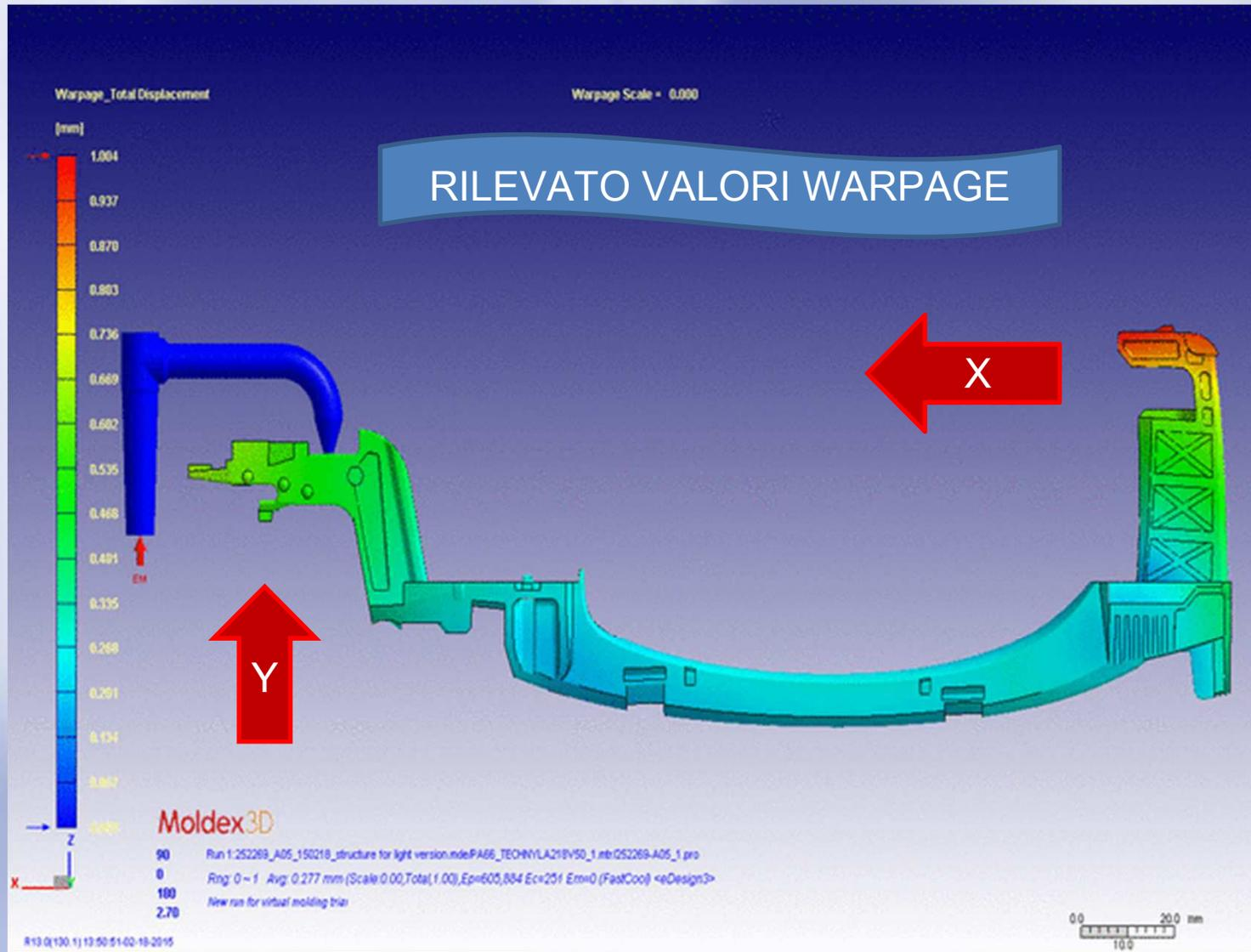

Creating and Offering the New Value



u-shin

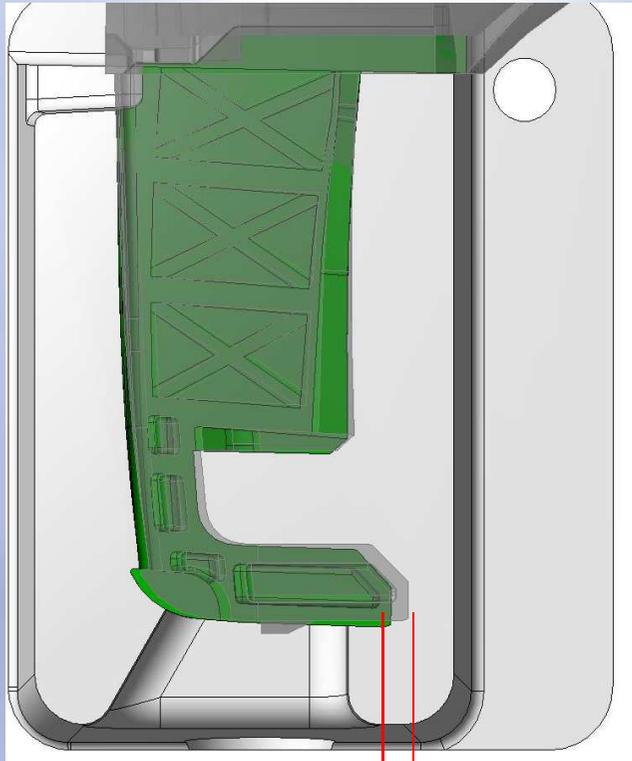
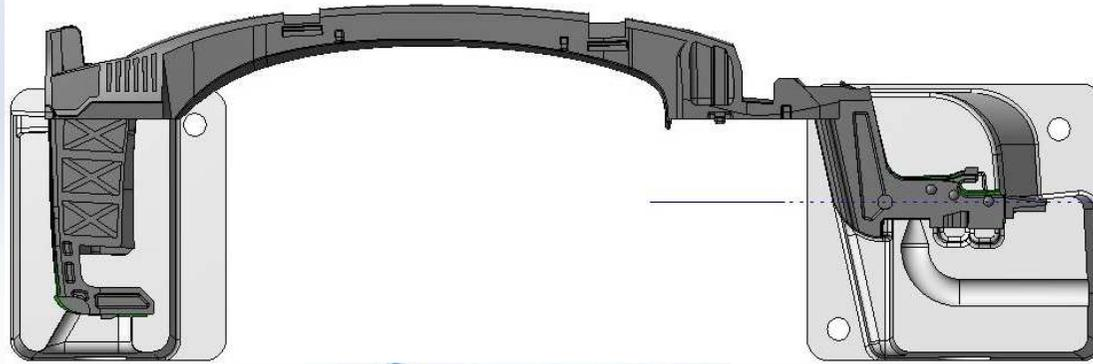

MODIFICATO 3D
STAMPO CON
VALORI
WARPAGE
UTILIZZANDO
STL WARPAGE
REVERSE DI
MOLDEX

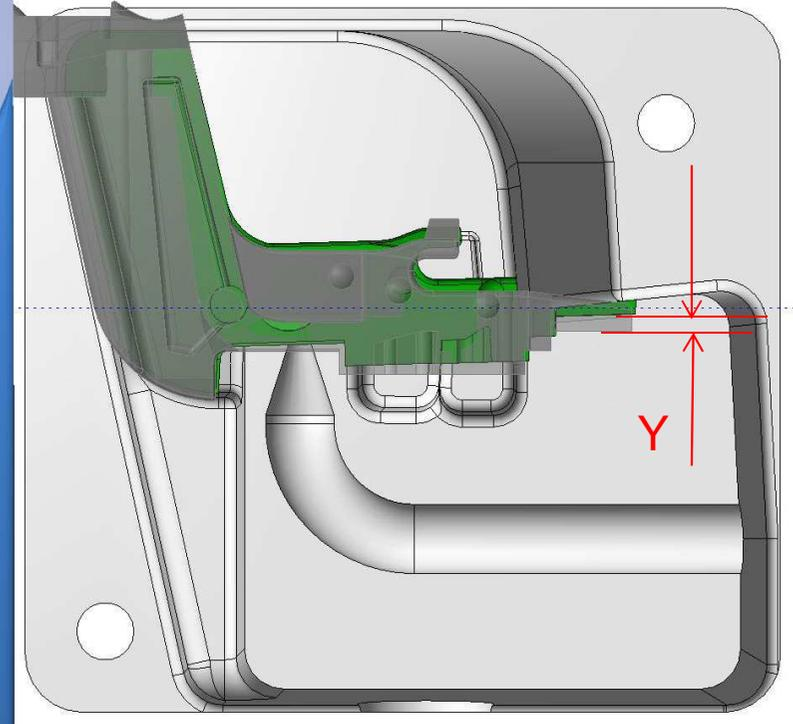

Creating and Offering the New Value



MISURE 3D DOPO FOT

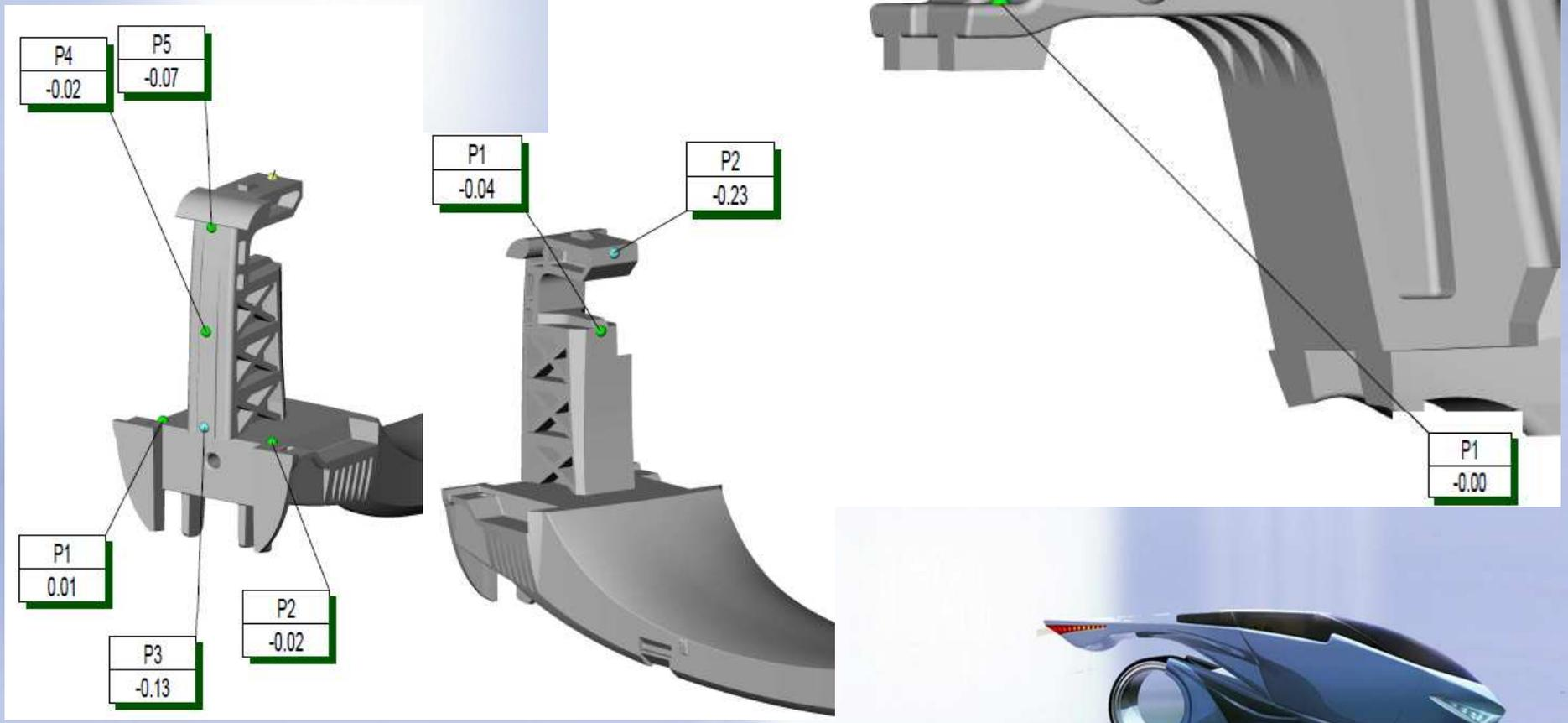

Creating and Offering the New Value



u-shin

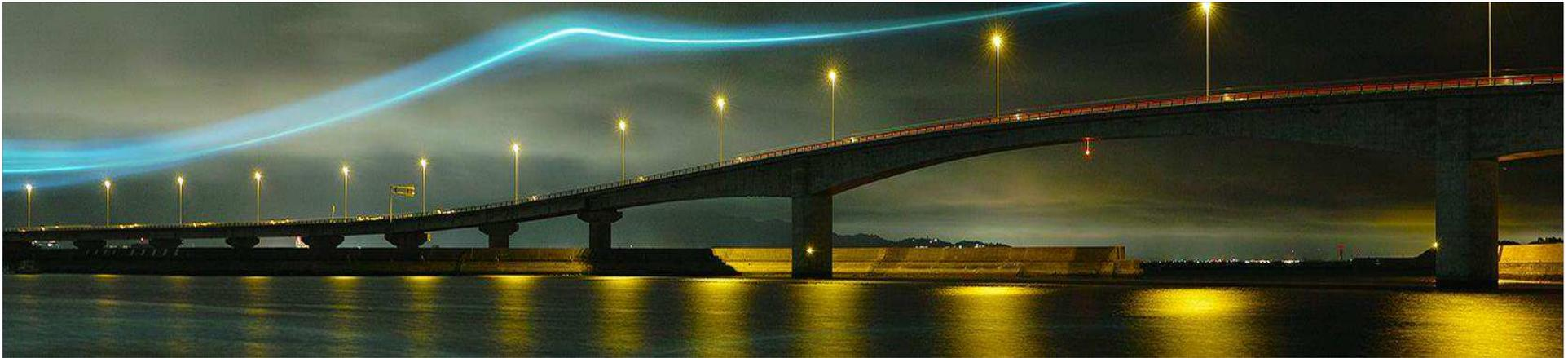

Thank you for your attention!!

Creating and Offering the New Value

